

ZC 3052

5 Axis CNC Machining Center



Kaban Makina Sanayi ve Tic. Ltd. Őti.

Hadımköy Atatürk Sanayi Bölgesi, Ömerli Mahallesi, 75.Yıl Caddesi, Uzunçayır Sokak, No:12, P.K. 34555 Arnavutköy İstanbul

www.kaban.com.tr

ZC 3052 5 Axis CNC Machining Center



- Robust mechanical structure suitable for high speed
- Axis velocities whose average exceed 100 m/min
- Profiling length 7630 mm
- Double station profiling length 3615 mm x 2
- Machinable profile section size 450 x 300 mm
- Number of clamps is 10
- Spindle motor 11-13.5 kW 24,000 rpm
- The number of magazine sets is 12 pieces
- Ø 400 mm saw
- Mitsubishi CNC control unit
- Automatic tool length measuring
- Automatic positioning vices
- Automatic tool recovery in case of power failure

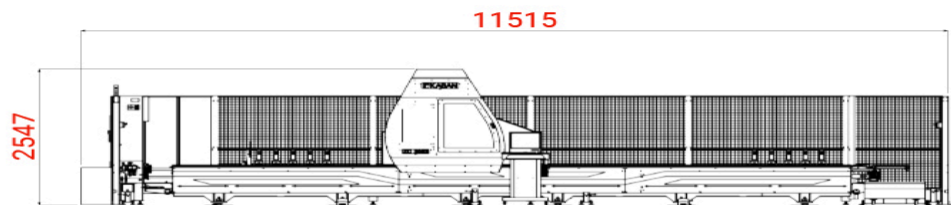
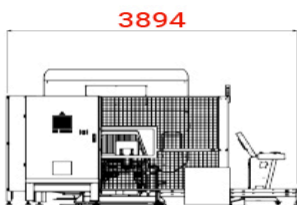
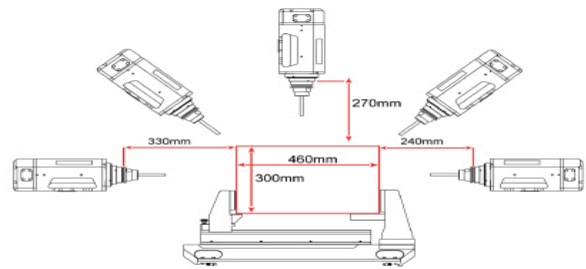
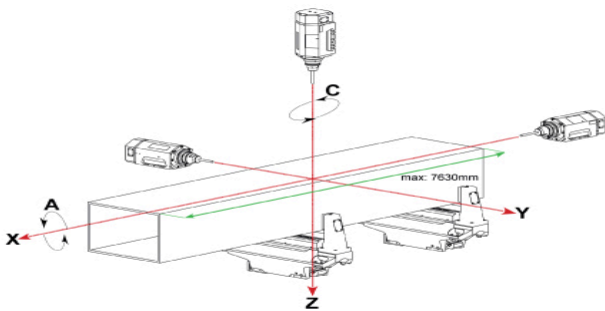

ZC 3052 5 Axis CNC Machining Center

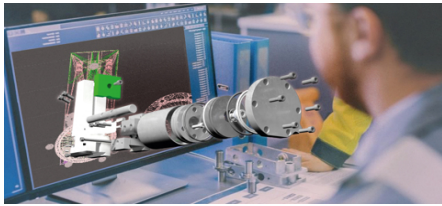

Design

- Mechanical structure that can process aluminum and steel profiles at high speed and high quality
- Stress relieved cast and welded parts to ensure consistent high speed accuracy
- Axis velocities whose average exceed 100 m/min
- Milling, notching, drilling, threading, countersinking, cutting, etc. ability
- Machining length in single station operation 7630 mm
- Machining length in double station operation 3615 mm x 2
- Machinable profile section size 450 x 300 mm
- Coolant spray system

Control Panel

- Versatile adjustable, ergonomic kiosk
- 19" screen
- User-friendly Kaban interface with Windows-based, easily adjustable parametric structure
- Compatibility with .NCX extension software
- High performance 4+1 axis Mitsubishi CNC control unit
- Communication via Ethernet
- Working with G-Code
- Data transfer via USB and COM Port

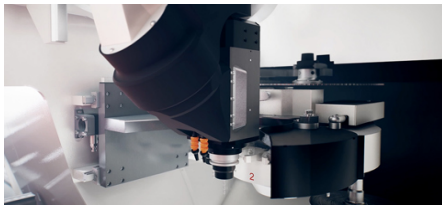

Spindle

- Servo-controlled positioning with increased torque
- Liquid cooled 8.5 kW 24,000 rpm spindle with thermostat sensor
- Tool cooling system with oil-air mixture spray speed adjustment, liquid level sensor
- Tool holder and tool holder cleaning system
- Tool change safety protocols written to minimize operator errors as much as possible

Magazine

- Magazine with a capacity of 12 tools.
- Tool change feature in maximum 4 seconds.
- It saves time by changing tools while moving from operation to operation on the part.
- Ø200mm saw can be mounted.

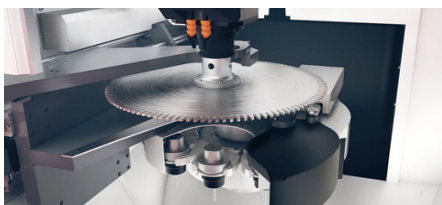
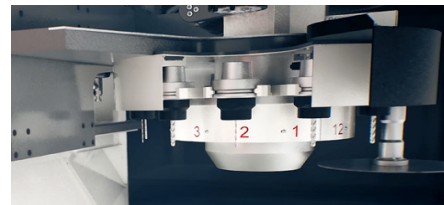

Saw Magazine

- It has a magazine for the saw
- Tool change feature in maximum 8 seconds
- Easy design for saw replacement
- Saws up to maximum Ø400mm can be installed

Automatic Tool Length Measuring

- Precise tool length measurement

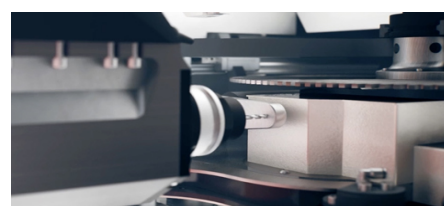

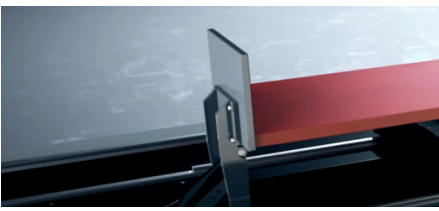

Profile Supports

- Automatic profile support system on both sides
- Suitable for working with long profiles

Vices

- Profile loading is very easy as the clamp fixings are on the front side
- There are 10 clamps as standard. The number of clamps can be increased as an option
- Since the surfaces on which the profile sits are roller system, it provides profile sliding comfort on the clamp surface
- According to the prescriptions on the workpiece, the clamps take servo-controlled automatic position
- Easy part resetting with double-sided profile resting system
- It offers the possibility to process profiles in long lengths. Ø400 mm saw can be used for notching the ends of the profiles
- Thanks to the pressure regulator, the clamp tightness can be adjusted according to the profile thickness
- Parts smaller than 300mm can be held and cut with a single clamp
- Thanks to the profile transport system with vice, the saw can easily enter between the profiles

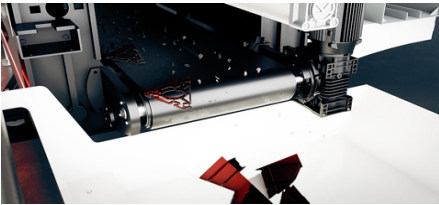

Chip Conveyor

- Chip conveyor for waste parts

Safety

- Ability to continue from where it left off in case of power failure with the UPS system
- Auto-recovery function that sends the spindle to the safe zone
- Operational safety with protective fences and safety barriers
- Security labels



Technical Support

- Periodic maintenance reminder function
- Service support with remote connection

ZC 3052 5 Axis CNC Machining Center

5 Axis Group	X Axis	Motor power	3,5	kW
	X Axis	Axis Speed	140	m/min
	X Axis	Machining Length	7630	mm
	Y Axis	Motor power	1,5	kW
	Y Axis	Axis Speed	80	m/min
	Y Axis	Machining Length	460	mm
	Z Axis	Motor power	1,5	kW
	Z Axis	Axis Speed	40	mm
	Z Axis	Machining Length	300	mm
	A Axis	Motor power	0,5	kW
	A Axis	Axis Speed	255	°/sec
	A Axis	Angle	±90	°
	C Axis	Motor power	0,5	kW
	C Axis	Axis Speed	255	°/sec
	C Axis	Angle	±180	°
Part Machining	Spindle	Motor power	8,5	kW
	Spindle	Rotation Speed	24000	cycle/min
Tool Warehouse	Tool magazine	Tool Number	12	Piece
	Saw	Diameter	200	mm
	Saw	Diameter	400	mm
Part Handling and Holding	Clamp	Axis Speed	15	m/min
	Clamp	Number of Clamps	10	Piece
Technical Specifications	Air	Pressure	6-8	Bar
	Air	Total Air Consumption	256	l/min
	Feed	Voltage	400	V
	Feed	Power	16,75	kW
	Feed	Current	42	A
	Weight	Net	10435	kg
	Weight	Gross	10600	kg
	Sound	Level	96	dB
	Machine Dimensions	Length	11515	mm
	Machine Dimensions	Width	3894	mm
	Machine Dimensions	Height	2547	mm

ZC 3052 5 Axis CNC Machining Center

Options



Barcode Printer

- Label printer for workflow tracking



Handwheel

- Manually moving the axes



Electronic Probe

- Dimension control of machined or to be machined parts